



Read these instructions before commencing installation. Please give these instructions to the owner/occupier after installation to retain for future reference/maintenance.

Available Rims: White, Chrome, Satin Chrom, Black or Matt Gold

IP54 IK05 0.3m 240V~50Hz 30W or 40W

These fittings are Class II and do not need an Earth.

**Important Information**

It is recommended that these luminaires are installed and fitted by a qualified electrician ensuring the installation complies with current IEE wiring regulations & local building control. These products are designed for connection to a 240V~50Hz supply.

Any faulty, broken or damaged luminaires should be replaced immediately.

KSR will not accept responsibility for any claims arising from a poor installation.

Please Note: The limited warranty shall be deemed null and void in the following circumstances: Failure by the installer, end user or any third party to exercise caution to protect any covered product or part from outside damage, adverse temperature (normal operating ambient temperature 0°C - +30°C), humidity conditions, fluctuations in the electrical system or physical abuse as well as failure related to workmanship in the installation of the products or parts.

**Important User Advice**

Always switch off mains supply before servicing.

Do not use Megger or similar high voltage instruments. Due to the fact this luminaire contains electronic components that maybe damaged by high test voltages, they must be disconnected from the circuit before testing.

To prevent damage to the driver, do not mix with conventional magnetic ballasts on the same electrical circuit.

At the end of life the luminaire is classed as WEEE under directive 2014/30/EU and should be disposed of in accordance with local legislation.

**Installation Procedure**

Isolate mains supply before installation.

Loosen locking screw located on side wall of body

With screw loosened twist diffuser anti clockwise and remove.

Pass intended supply cable(s) through the grommet ensuring a good quality seal around the cable(s) to preserve the IP54 rating never pass 2 cables through the same hole in the grommet as this will allow moisture to enter the luminaire through the gap between the cables reducing the IP rating to IP20.

Ensure the fixing surface is flat and even.

Fix base to the wall or ceiling (Fig.1) using adequate fixings with regard to the type of substrate.

Ensure incoming cables are protected.

Terminate wiring as per Fig. 2.

Select Wattage using the Switch on the Driver (Fig.3) & Select LED colour required using the toggle switch Fig. 4 on the LED board: Please Note never change the LED colour with the luminaire powered on as this can damage the luminaire. Make sure the seal is in place in the diffuser and undamaged.

Replace the diffuser re-secure with a clockwise twist followed by tightening the locking screw.

Turn on the mains supply and test luminaire. If using an optional rim clip the rim over the diffuser.

A 24 Hour initial charge period is required prior to any emergency testing, please see overleaf for testing routine, write on the battery label in permanent ink the date of commissioning.

All results must be recorded and left with the end user.

The battery has a design life of at least 4 years but should be replaced if the duration of operation is less than 3 hours after a 24hr charge time with no interrupted supply.

\*Please note: Depending on the amount of fittings on a circuit you may have to upgrade the breaker to a 'C' or 'D' type to avoid nuisance tripping.

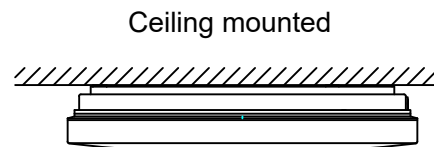

Fig. 1

Wall mounted

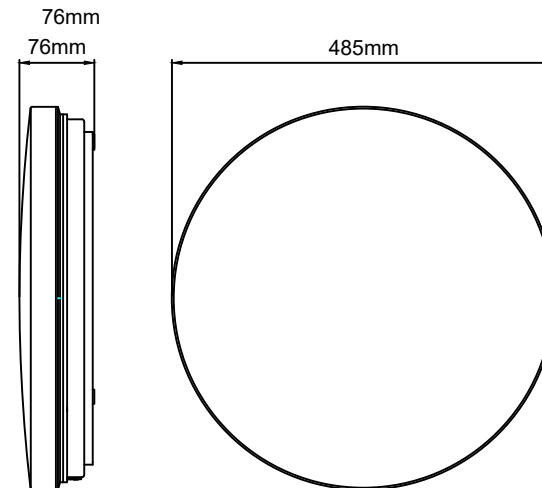
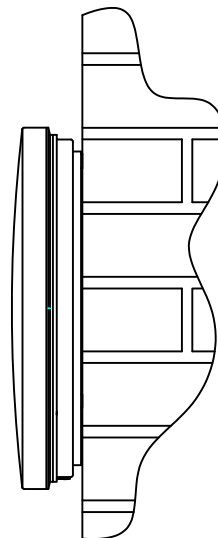

Fig. 2

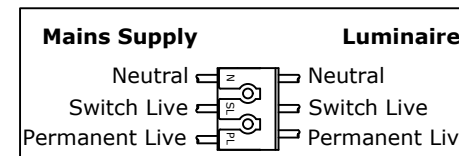

Fig. 3

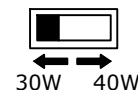
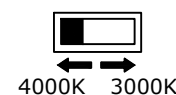

Fig. 4



**Lamp Details**

Lamp: LED  
 Wattage: 30W or 40W  
 Colour: 3000K or 4000K  
 CRI: Ra>80

| Wattage | Lumen output |        |
|---------|--------------|--------|
|         | 3000K        | 4000K  |
| 30W     | 2875lm       | 3045lm |
| 40W     | 3675lm       | 3905lm |



*This product contains a light source of energy efficiency class F  
 The LED light source and Control Gear in this product can be replaced by a professional.*



All tests must be undertaken at times of least risk and in accordance with EN 50172:2004 as indicated below:

**Daily:**

LED charge indicators shall be visually inspected for correct operation.

**Monthly:**

(in addition to the daily check) If automatic testing devices are used, the results of the short duration tests shall be recorded.

Test shall be carried out as follows:

1. Switch the luminaire over to emergency mode to operate from the batteries by simulating a failure of supply to the emergency circuit for a period sufficient to ensure correct luminaire operation.

**Note:** The period of simulation failure should be sufficient for the purpose of this clause whilst minimising damage to the system components e.g lamps. During this period, all luminaires shall be checked to ensure that they are present, clean and functioning correctly. At the end of this test period, the unswitched supply should be restored and any indicator lamp or device should be checked to ensure that is showing that the supply has been restored.

**Annually:**

If automatic testing devices are used, the results of the short duration tests shall be recorded. For all other systems the monthly inspection shall be carried out and the following additional tests made:

1. Each luminaire shall be tested monthly as above but for its full duration in accordance with the manufacturer's information.
2. The unswitched supply for the luminaire should be restored and any charge indicator lamp or device should be checked to ensure that it shows the unswitched supply has been restored. The charging arrangements should be checked for proper functioning.
3. The date of the test and its results shall be recorded in the system logbook.

A copy of this report must accompany any emergency luminaire returned to KSR Lighting for any reason.



